



BUILDING PRODUCT INFORMATION SHEET (CLASS 2)

Product name:

Fairview One (FVONE)

Product Description and its intended use:

FVONE uses a combination of flush surfaces, square shapes and timber liners to give the suite a clean modern aesthetic.

FVONE has been designed for projects ranging from mid to high-end homes, multi-unit developments, and low-rise commercial projects to education.

FVONE is custom fabricated to the requirements of each project. With a 36mm glazing platform, FVONE provides a glazing capability of 3mm to 26mm (min-max). The product range consists of:

- Fixed, awning and casement windows
- Bi-fold windows
- Sliding windows
- Hinged doors
- Bi-fold doors
- Sliding doors
- Stacking doors

Product Identifier:

Fairview One (FVONE)

Place of Manufacture:

New Zealand

Legal and trading name of the manufacturer:

FMI Building Innovation Limited

Address for Service:

2-6 Timaru Place Mt Wellington 1060

PO Box 51075 Pakuranga 2140

Auckland

Website:

www.fmi.co.nz

Email address:

info@fmi.co.nz

Phone No.:

+64 9 574 2900

NZBN:

9429039520364

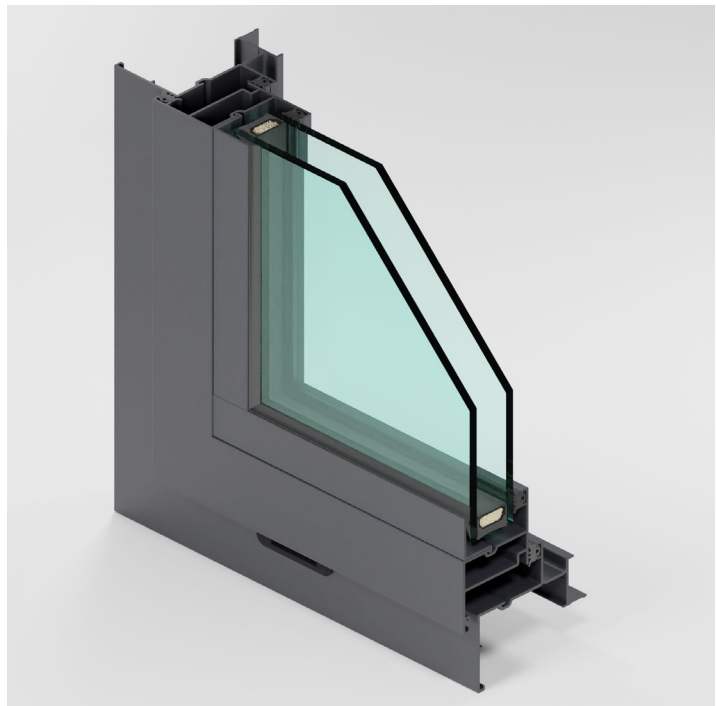



Relevant Building Code Clauses:

- B1 Structure: Performance clauses B1.3.1, B1.3.2, B1.3.3 B1.3.4.
- B2 Durability: Performance clauses B2.3.1(b) and B2.3.2.
- E2 External Moisture: Performance clause E2.3.2 and E2.3.7.
- F2 Hazardous Building Materials: Performance clauses F2.3.1, F2.3.2, F2.3.3.
- F4 Safety from Falling: Performance F4.3.1 and F4.3.4.
- G4 Ventilation: Performance clause G4.3.1 and G4.3.3.
- G7 Natural Light: Performance G7.3.1 and G7.3.2.
- H1 Energy Efficiency: Performance clauses H1.3.1, H1.3.2E and H1.3.3.

Statement on how the building product is expected to contribute to compliance:

- **B1.3.1, B1.3.2, B1.3.3 and B1.3.4:** FVONE has been tested in accordance with NZS 4211:2008. FVONE is glazed to comply with NZS 4223.3:2016 where specified in the Project requirements because human impact may occur.
- **B2.3.1(b) and B2.3.2:** FVONE can be finished to provide a durability of at least 15 years in all Exposure Zones. Durability is dependent on FVONE being installed and maintained in accordance with FMI Care & Maintenance requirements. Glazing complies with the requirements of NZS 4223.2: 2016.
- **E2.3.2 and E.2.3.7:** FVONE has been tested in accordance with NZS 4211:2008. FVONE is suitable for installation in accordance with Acceptable Solution E2/AS1, Third Edition Amendment 10, and can be supplied with sill support bars or support blocks to suit the cladding selection.
- **F2.3.1, F2.3.2 and F2.3.3:** FVONE is safe when handled in accordance with installation instructions. FVONE is fabricated to comply with NZS 4223.3:2016 where specified in the project requirements.
- **F4.3.1 and F4.3.4:** FVONE is fabricated with opening restrictors to comply with F4/AS1 Third Edition Amendment 2, Paragraph 2.0 Opening Windows, where relevant considerations are specified in the project requirements.
- **G4.3.1 and G4.3.3:** FVONE can be fabricated with opening sashes of type and dimensions specified in the project requirements to help provide building ventilation. The calculation of window opening areas for Ventilation shall be in accordance with Acceptable Solution G4/AS1.
- **G7.3.1 and G7.3.2:** FVONE can be fabricated with an area of transparent glazing suitable to give awareness of the outside and provide natural light in habitable spaces. Glazing design may comply with G7/AS1 Second Edition or G7/AS2 First Edition.
- **H1.3.1(a), and H1.3.2E:** FVONE is a non-thermally broken system which can be fabricated with IGUs made from a range of possible glass, spacer and infill gas types, to suit the window insulation (R-value) requirements of the project. FVONE will achieve R-values in accordance with either H1/AS1 Fifth Edition Amendment 1, Table E1.1.1, or with H1/VM1 Fifth Edition Amendment 1, Paragraph E1.



Relevant standards:

FVONE, and/or its component parts, are tested, fabricated and specified to comply with the following standards, as relevant to the project specifications:

- NZS 4211:2008 Specification for the performance of windows
- NZS 4223 Code of practice for glazing in buildings - Part 1:2008 Glass selection and glazing
- NZS 4223 Code of practice for glazing in buildings - Part 2:2016 Insulating glass units
- NZS 4223 Code of practice for glazing in buildings - Part 3:2016 Human impact safety requirements
- NZS 4223 Code of practice for glazing in buildings - Part 4:2008 Dead, wind and snow loading
- NZS 3602:2003 Timber and wood-based products for use in buildings
- AS 3715:2002 Metal finishing – Thermoset powder coatings for architectural applications of Aluminium and Aluminium alloys.

Limitations on the use of the building product:

- FVONE is not fire resistant and cannot provide a fire resistance rating.
- FVONE is not suitable for use where recommended maintenance cannot be reasonably achieved.

Design requirements that would support the use of the building product:

FVONE is designed for, but is not limited to, use in projects within the following scope:

- Housing and residential apartment buildings, and their associated ancillary and outbuildings.
- All Wind Zones up to and including Extra High.
- All Exposure Zones, except in microclimates where there is evidence of corrosion in adjacent structures caused by industrial or geothermal atmospheres.
- Maximum IGU thickness is 26 mm.
- Design and installation that follows common Acceptable Solutions such as E2/AS1, F4/AS1, G4/AS1, G7/AS1 and H1/AS1.
- Anodised or powdercoat finish to Aluminium, selected from the FMI Building Innovation Ltd available colour range.
- Timber reveals pre-primed for site painting, unless otherwise agreed with FMI Building innovation Ltd.

FVONE may be used in projects outside this scope if other parties such as architects or cladding system suppliers establish appropriate design and installation requirements. Subject to FMI Building Innovation Ltd Technical and Specification Team review and approval.

FVONE achieves an air infiltration rating for air-conditioned buildings (determined in accordance with NZS 4211:2008). Controlling air permeability and infiltration helps prevent heat losses from buildings.

FVONE is custom fabricated to the requirements of each project. Prior to fabrication, the following project selections must be confirmed by the specifier:



- Unit size.
- Opening panel size(s) and type(s), and configuration of fixed and opening panels, including any specific requirements for doors that are on access routes or escape routes.
- Project Wind Zone.
- Project Exposure Zone.
- IGU performance selections, including R-value, solar heat gain (SHGC), VLT, and safety glazing requirements.
- Safety fittings and hardware: restrictors, door closers and swimming pool barrier latches to be fitted where an opening window or door requires features for safety from falling or is within a wall that forms part of a residential pool barrier.
- Finish requirements and colour for Aluminium components.
- Any special requirements for timber reveals. Default specification is pre-primed finger-jointed radiata pine H3.1 treated, suitable for paint finish.

Installation requirements:

- Ensure that the joinery is protected from dust, debris, and moisture if stored prior to installation.
- Inspect joinery thoroughly before beginning installation to ensure it is free from any defects and damage, including damage caused during transit and delivery.
- Check the dimensions and fit of each unit against the rough opening.
- Install the door in accordance with the consented or design drawings and with FMI Building Innovation Ltd installation requirements available from <https://fmi.co.nz/technical/>.
- Ensure door and window units are installed plumb, level, and in plane, within the tolerances set out in the MBIE Guide to materials, tolerances, and workmanship in residential construction.
- Check and adjust all seals and operating hardware to ensure good fit and proper operation and function without jamming or gaps.
- Ensure drain holes are clear of dirt and debris following installation.

Maintenance requirements:

- Exterior surfaces of FVONE should be washed using a mild soap, warm water and quality soft-bristled brush or cloth.
- How often:
 - Coastal - clean every 3 months
 - Geothermal - clean every 3 months
 - Industrial - clean every 3 months
 - Rural - clean twice a year
 - Residential - clean twice a year



- All drain holes in FVONE should be cleaned every three months from any debris.
- All sliding door tracks and bi-fold doors should be cleaned and free from debris every three months.
- Condensation on FVONE can be reduced by removing or limiting moisture sources and improving ventilation.
- Hardware on FVONE should be washed every month with a mild cleaner like dishwashing liquid mixed with warm water. Adjust and lubricate the hardware as directed by the supplier. Hinges and window stays should be cleaned at the same time as the aluminium joinery, with a mild cleaner.
- Seals, gaskets, rubbers, rollers and other components of FVONE should be checked for proper fit and operation and replaced if damaged.
- Glass surfaces of FVONE may be cleaned with a sponge or soft cloth and warm water with mild detergent, or with proprietary glass cleaning products. Abrasive materials should not be used to clean or wipe glass, as this will cause damage to the glass surface.

Is the building product/building product line subject to warning or ban under section 26?:

No

If yes, description of the warning or ban under section 26:

N/A

Date

20 November 2023

Version	Date	Description of changes
1.0	20/11/2023	Published